



# CONTROL PANEL

## “50A806” Model Simplex 115/230V 1 Phase Time Dosing Panel

### Features & Benefits

- Circuit Breaker for Pump Circuit
- Definite Purpose Motor Contactor
- Easy to Access Terminal Block
- Usable with 115/230 VAC 1PH Power
- Alarm Silence & On-Off-Test Switches
- Externally Mounted Audible Alarm
- Pump Hand-Off-Auto Switch
- Pump Running Light
- Repeat Cycle Timer
- Large External Alarm Light
- Control Circuit Fuse Protection
- Ground Lugs
- Color Coded Internal Wiring
- Rugged Weather Resistant Hinged Poly Enclosure w/Sst Latches
- Built and Labeled to UL 508A Standard w/Nema 4x Rating
- Provided with Wiring Schematic and Detailed Connection Diagram for Installer
- Mounting Feet for Enclosure

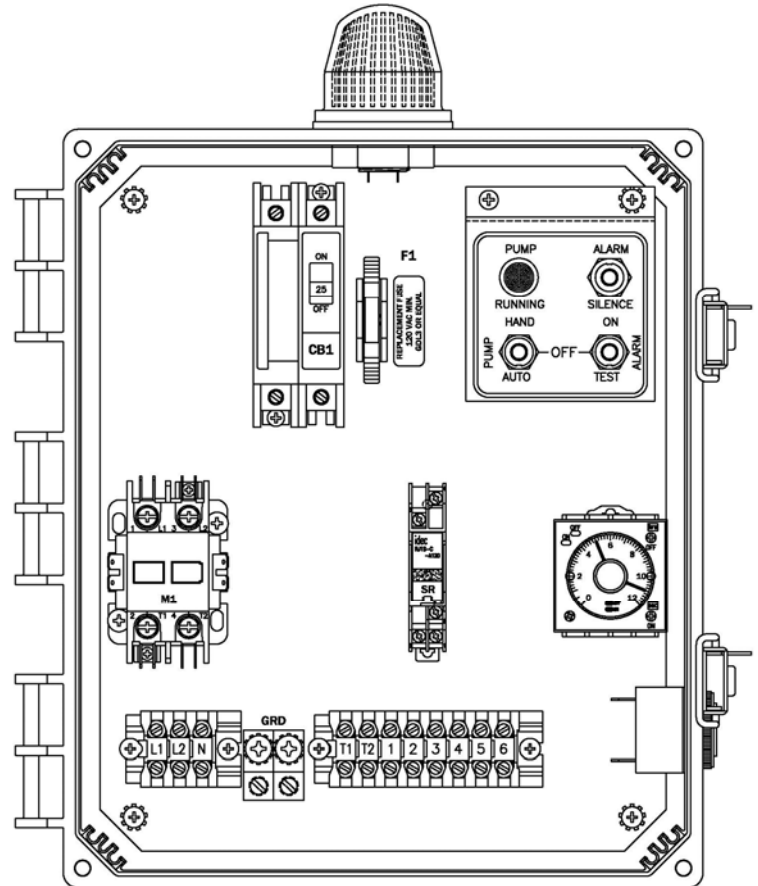

(Standard 50A806 Model Shown)

### Available Options(\*)

- Fiberglass Enclosure
- IEC Motor Contactor
- Flasher
- Dead Front Inner Door
- Auxiliary Alarm Contacts
- Elapsed Timer Meters
- Event or Cycle Counters
- Mercury or Mechanical Float Switches for the Pumps and High Water Alarm Circuits



\*Note: Consult the factory for other available options. Also, some options may require an increase in the enclosure size.

**“50A806” Model Simplex 115/230V 1 Phase Time Dosing Panel**

**Panel Dimensions**

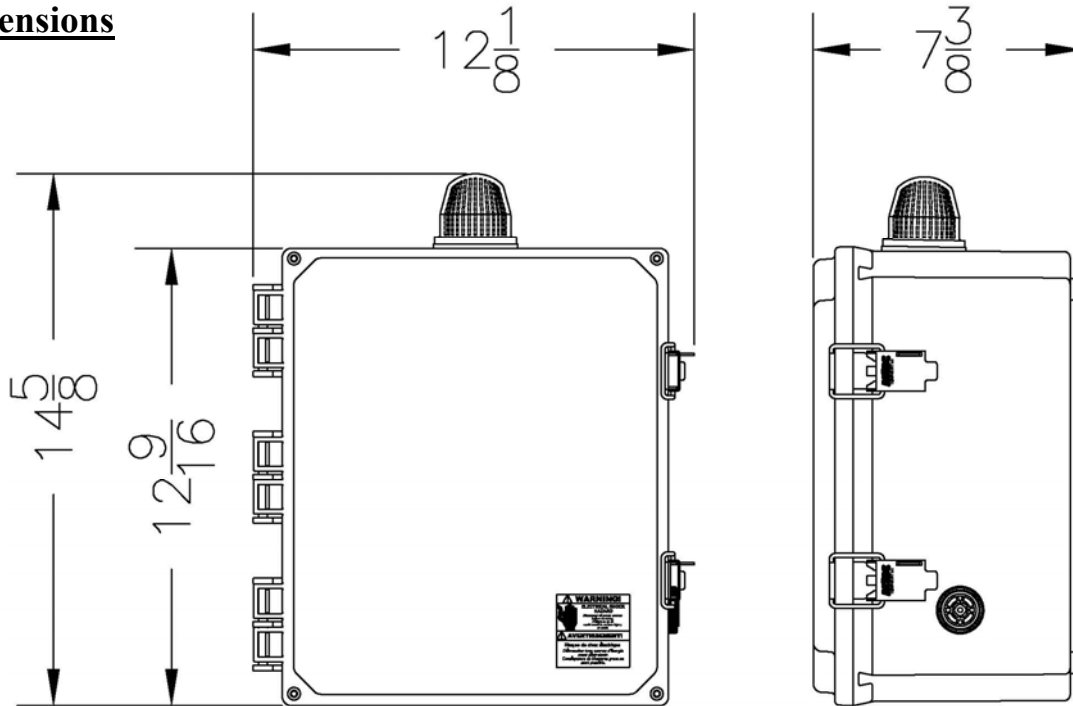

**Panel Schematic**

